

# 8.1 LT INDUSTRIAL STATIONARY

150 kw @ 1800 rpm / 130 kw @ 1500 rpm

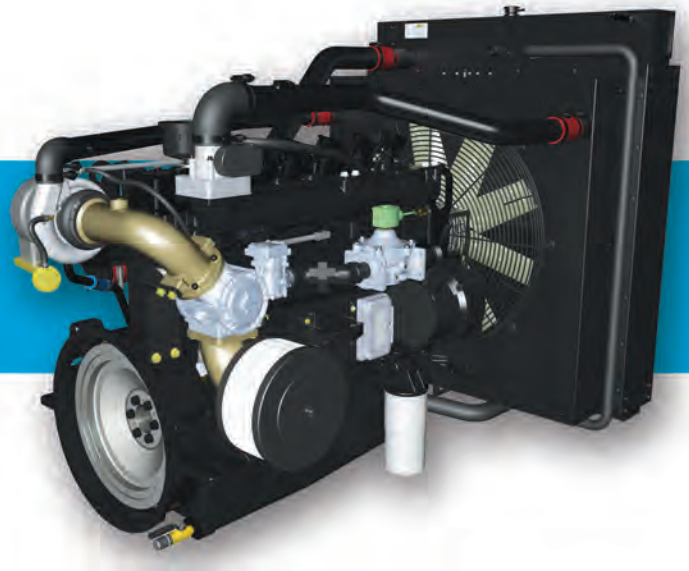

The PSI HD 8.1L Turbo is a U.S. EPA-certified natural gas and propane engine developed from the block up to be a reliable and durable power unit. Built upon a proven marine-diesel grade block, the 6-cylinder V-Configuration, turbocharged and after-cooled engine features replaceable dry liners and water-cooled exhaust.

Superior engine performance is driven by an ECU that integrates and coordinates all critical functions including: Governor, Variable Ignition Timing, Air Fuel Ratio Control, Knock Suppression and Engine Protection.

The PSI HD product lineup has six models with displacements of 8.1L, 11.1L, 14.6L, 18.3L and 21.9L. These engines are an extension of the PSI product line, which is based upon blocks from 650cc to 8.8L. All PSI engines feature the same fuel systems and controls, simplifying your application development and support.

## GENERAL DATA

- Water-cooled, turbo-charged, air-to-air inter-cooled, stoichiometric with replaceable dry cylinder liners
- Cast iron block & heads, 10.5:1 compression ratio, overhead valve/2V configuration
- Crankshaft gear-driven oil system with cartridge-type filter, belt-driven centrifugal water pump
- 24VDC Starter and Alternator
- CANBUS J1939 interface
- 3-Way Catalytic Converter
- UL-recognized air filtration
- Integrated knock sensing and control
- Full ECU engine control with coil-on-plug variable timing ignition
- Engine protection for oil pressure, coolant level, coolant temperature, fuel pressure, over-speed

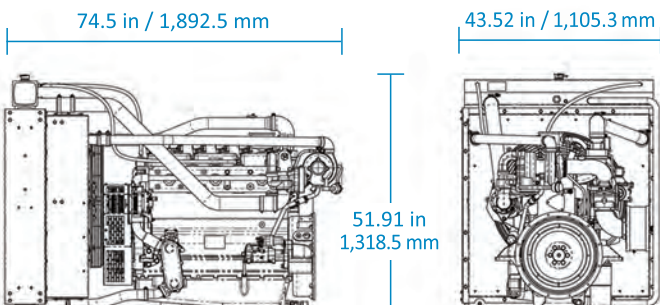

## FEATURES

- U.S. EPA-Certified and CARB-Compliant, Industrial Stationary
- 50C Ambient Cooling Capacity
- UL2200-Compliant or Listed Components
- MasterTrak Telematics service (included for 1 year)

## GENERATION 2 ENHANCEMENTS

- Enhancements for prime & continuous power
- Dual Fuel Auto Switch-Over
- Brushless Alternators
- Serpentine, Self-Tensioning Fan Belt
- Advanced diagnostics for improved up-time

## PSI 8.1-LITER TURBO ENGINE DATA

Cylinders	V-6, in-line
Induction system	Turbocharged & air-to-water charge-cooled
Combustion system	Spark-ignited
Cooling system	Water-cooled
Displacement	492 cid (8,064 cc)
Compression ratio	10.5:1
Bore & Stroke	4.37 in x 5.47 in (111 mm x 139 mm)
kW (flywheel)	150 kw @ 1800 rpm / 130 kw @ 1500 rpm (Natural gas)
Fuel Type	Natural Gas / Propane
Direction of rotation	Anti-clockwise viewed on flywheel
Dimensions – Length	1,892.5 mm (74.5 in)
Width	1,105.3 mm (43.52 in)
Height	1,318.5 mm (51.91 in)
Dry Weight	998 kg (2,200 lb)